



# Mesh Node, Benchtop



The **Mesh Node · Benchtop** is a compact Xtensa® **ESP32-S3** test platform featuring the Ebyte **EoRa PI** mainboard with **E22-400MM22S** (Semtech® **SX1268**) LoRa® module, plus the Beitan **BN-220** GNSS module (U-Blox **M8030**). Built-in UPS with 6Ah Li-ion capacity for both desktop and field use. Out-of-the-box compatible with MeshCore, Meshtastic, and other mesh firmware. A flexible  $\frac{1}{2}\lambda$  915 MHz whip antenna is included. Easy development via USB/serial, SD card, Wi-Fi, or BLE.

## ✓ Features

- **Ebyte EoRa PI Mainboard.** Xtensa ESP32-S3 MCU with Ebyte E22-400MM22S (Semtech LoRa SX1268) radio module.
- **GNSS.** Beitan BN-220 module (U-Blox M8030) connects to 3 GNSS constellations simultaneously.
- **Integrated UPS.** 6Ah Li-ion cells (5V 2A power source, not included) for extended desktop or field operation.
- **Mesh Firmware.** Out-of-the-box MeshCore and Meshtastic compatible.
- **Connectivity.** USB/Serial, SD card, WiFi and BLE. Flexible  $\frac{1}{2}\lambda$  SMA whip antenna tested for 915 MHz operations.

## 🔧 Applications

- Lab and shop firmware development and testing.
- Portable mesh network node.
- Field LoRa mesh deployments.
- Battery-backed long-duration testing.
- Rapid mesh hardware validation.
- Off-grid and emergency communication testbed.
- Industrial sensor telemetry extension.
- Search-and-rescue support node.

## 🌐 Resources

- [Xtensa ESP32-S3 Datsheet](#)
- [Ebyte EoRa PI User Manual](#)
- [Ebyte E22-400MM22S User Manual](#)
- [Semtech SX1268 Datasheet](#)
- [Beitan BN-220 GNSS Datasheet](#)
- [U-Blox M8030 Summary](#)

## 🏪 Availability

- Production samples are available from the [Project Tarn Sample Store](#).
- The design is available for licensing — exclusive or non-exclusive manufacturing and distribution licenses are available; please contact <mailto:licensing@tarn.parts> for more information.

⚠️ **Advisories:** Licensing and distribution to countries, entities and individuals is subject to United States, United Kingdom, European Union, and Canadian regulation and export control. No specific technical or jurisdictional regulatory certifications or approvals are implied or warranted except those explicitly indicated alongside the availability of a specific retailer or distributor and for the specific jurisdiction(s) indicated. Unless otherwise indicated, samples obtained from the Tarn Sample Store are non-certified manufacturing/production commercial samples for evaluation and testing purposes only; consumer resale and re-export is strictly prohibited. Copyright © 2026 Tarn Design and Production; Calgary, Alberta. All rights reserved. All trademarks, trade names, logos, and product names referenced in this datasheet are the property of their respective owners and use thereof does not imply endorsement or affiliation. While all reasonable attempts for accuracy has been maintained as of the date indicated below, the data, illustrations and descriptions herein may not be exactly as shown and are subject to change without notice.

## Diagram

The **Ebyte EoRa-PI** mainboard is built around the Xtensa ESP32-S3 MCU, with bidirectional interfaces to the Beitan BN-220 GNSS module (left) and the Ebyte E22-400MM22S LoRa module featuring the Semtech SX1268 transceiver. A UPS power supply block, fed by dual 18650 Li-ion cells, provides the system voltage.

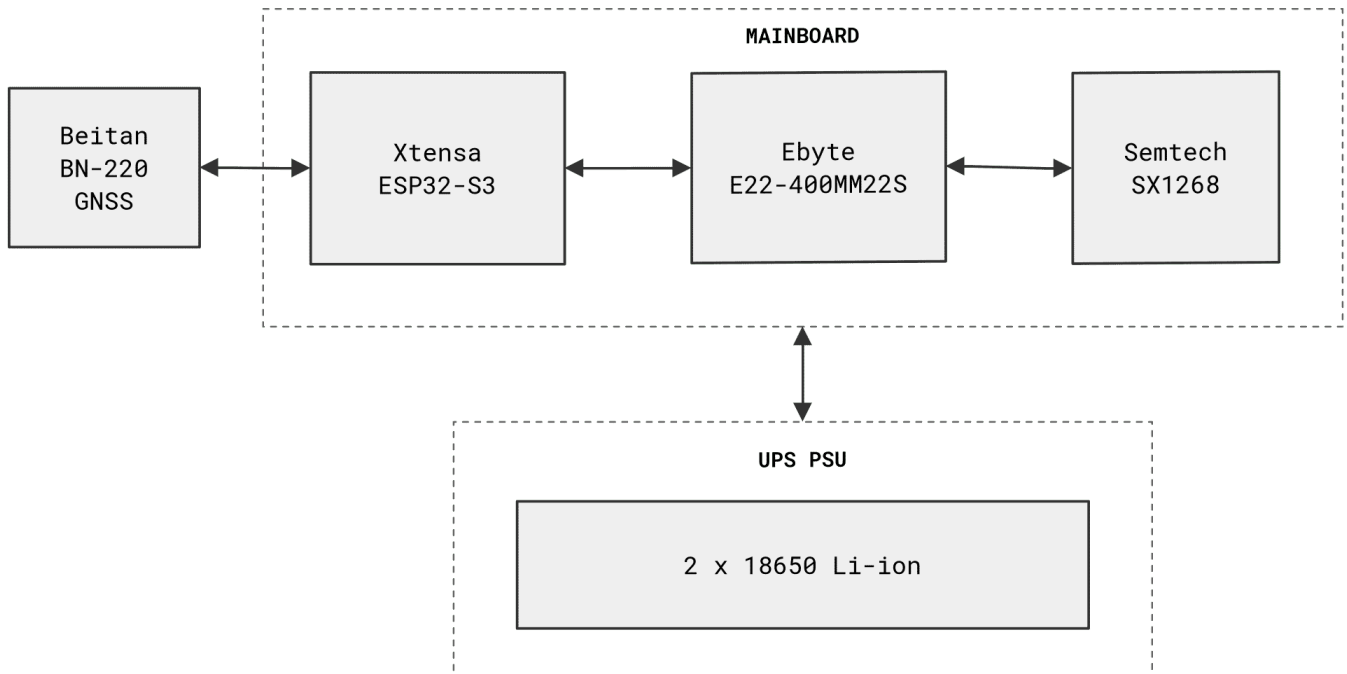

## Dimensions

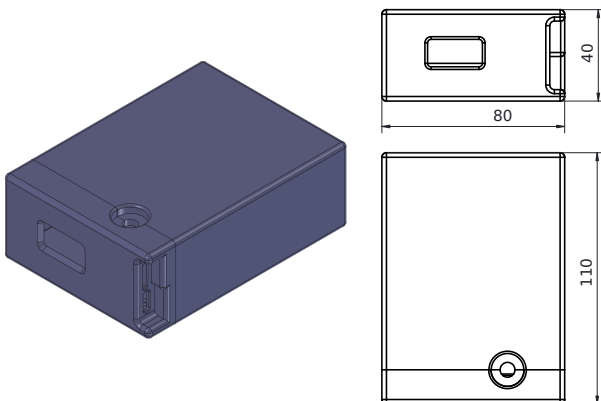

- Weight: **350 g**
- Dimensions: **110 × 80 × 40 mm**
- Antenna: **170 mm**
  
- Packaging: **Cardboard Carton**
- Package Weight: **0.5 kg**
- Package Dimensions: **15 × 15 × 5 cm**

## ⚠ Attention

- Always connect the antenna before powering on the device.
- Do not expose to water or extreme temperatures.
- Use only approved 5V USB power source.
- Handle Li-ion cells with care; avoid short circuits.
- Disconnect battery if storing long term.

## i Regulatory

- Samples obtained from the Tarn Sample Store are non-certified manufacturing/production commercial samples for evaluation and testing purposes only; consumer resale and re-export is strictly prohibited.

---

## 📄 Quick Start Guide · Mesh Node, Benchtop

1. Fully charge the device via 5V USB (UPS will charge the included 18650 cells).
2. Ensure the  $\frac{1}{2}\lambda$  whip antenna is securely connected.
3. Power on the device.
4. Connect via USB Serial, WiFi or BLE to your computer or mesh app.
5. Verify MeshCore or Meshtastic firmware and test LoRa link.